

**Gel Series SLA Battery**

**Gel Series**

Gel series batteries are designed to meet the requirements of frequent cyclic and high temperature applications such as broadband, PVs etc through up-to-date gel technologies. BOSFA Gel batteries uses German origin high purity fumed silica to form sulfuric acid thixotropic Gel and fills to the batteries with vacuum to ensure the fully penetration of electrolyte through separators and plates pastes.

**Application**

- Alarm System
- Cable Television
- Communication Equipment
- Control Equipment
- Security System
- Medical Equipment
- UPS
- Power tools
- Emergency Power System
- Toys

**General Features**

- Sealed and maintenance free operation.
- Non-Spillable construction design.
- ABS containers and covers(UL94HB, UL94V-0) optional.
- Safety valve installation for explosion proof.
- High quality and high reliability.
- Exceptional deep discharge recovery performance.
- Low self discharge characteristic.
- Flexibility design for multiple install positions.

**Construction**

- |           |                   |              |                                    |
|-----------|-------------------|--------------|------------------------------------|
| Component | .....Raw material | Sealant      | .....Epoxy Resin                   |
| Positive  | .....Lead dioxide | Safety valve | .....EPDR                          |
| Negative  | .....Lead         | Terminal     | .....Copper                        |
| Container | .....ABS          | Separator    | .....Macromolecule polymer         |
| Cover     | .....ABS          | Electrolyte  | .....sulfuric acid thixotropic Gel |

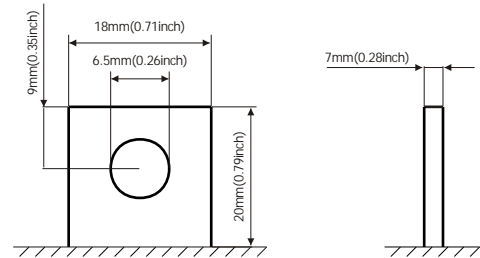

**Terminal Dimensions**

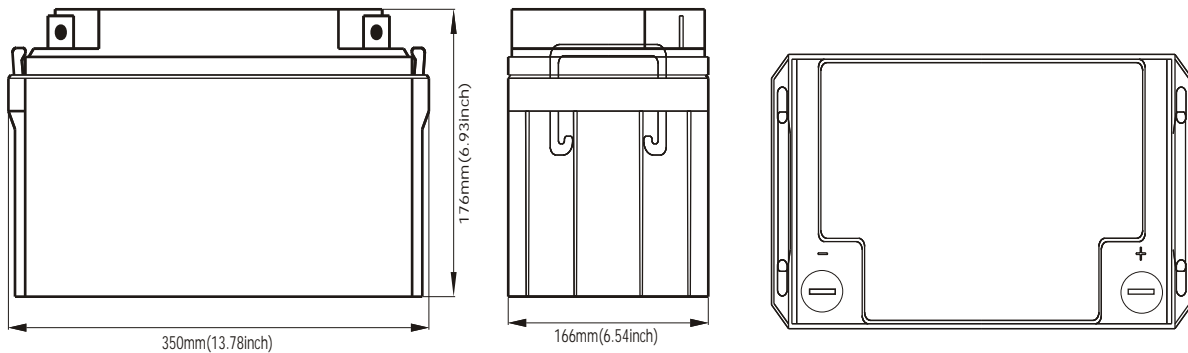

Battery Model	GEL12-65			
Designed Life	10 Years (Floating) or > 750 Cycles @ 50% D.O.D			
Capacity(25°C)	20HR(3.25A,1.75V)	10HR(6.4A,1.75V)	5HR(10.8A,1.75V)	1HR(39A,1.75V)
	65AH	64AH	54AH	39AH
Dimensions	Length	Width	Height	Total Height
	350mm(13.78inch)	166mm(6.54inch)	176mm(6.93inch)	176mm(6.93inch)
Approx. Weight	21.6Kg (47.63 lbs)			
Internal Resistance	Full charged at 25°C: 0.0058 Ohm			
Self Discharge	3% of capacity declined per month at (25°C)			
Capacity Affected by Temp.(20HR)	40°C	25°C	0°C	-15°C
	102%	100%	85%	65%
Charge Voltage(25°C)	Cycle use		Float use	
	14.4-15V(-30mV/ °C), max. Current: 16.25A		13.6-13.8V(-20mV/ °C)	

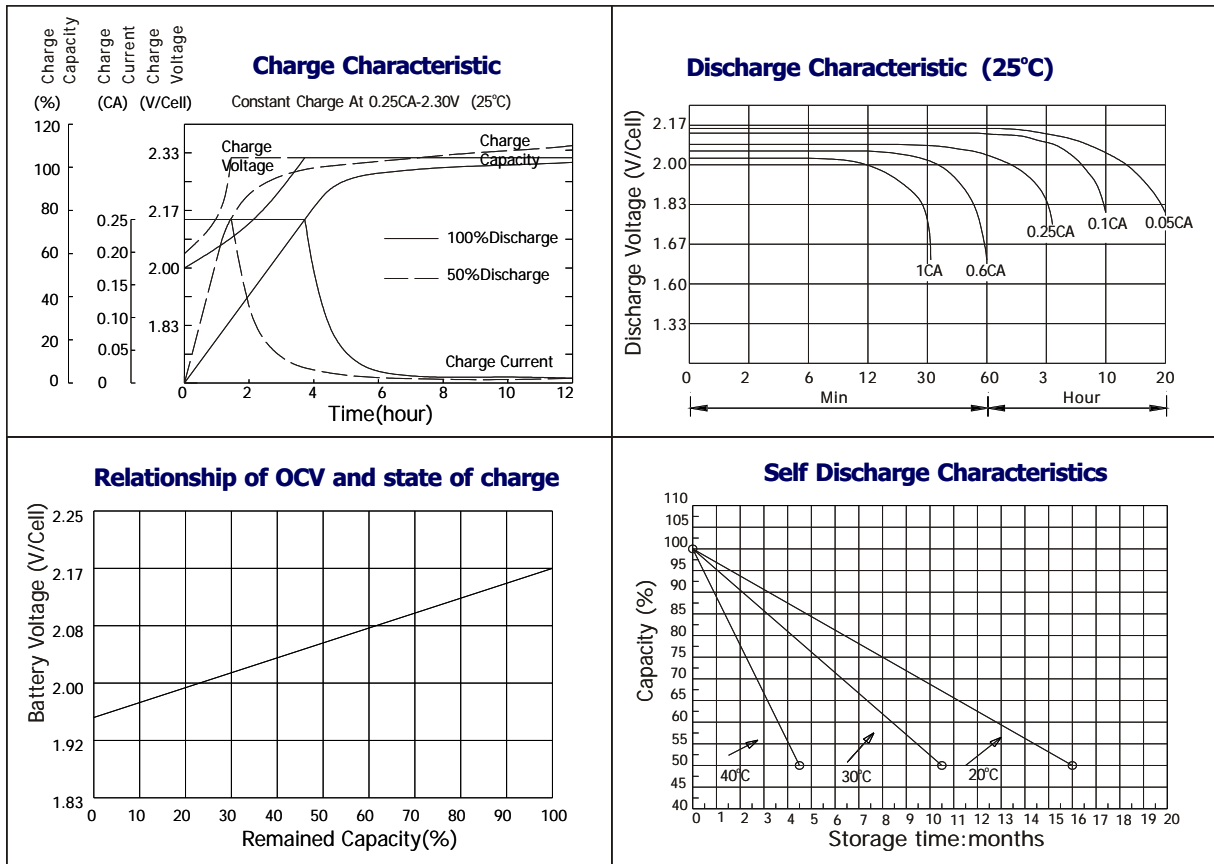

**Constant current discharge ratings-amperes at 25°C**

F. V/Time	5MIN	10MIN	15MIN	30MIN	1HR	3HR	5HR	10HR	20HR
1.60V	228	156	114	68.3	42.9	17.7	12.4	6.89	3.43
1.67V	205	142	111	66.3	42.8	17.7	12.3	6.79	3.41
1.70V	194	137	107	65.0	42.7	17.7	12.3	6.74	3.41
1.75V	173	127	101	63.7	42.3	17.6	12.2	6.62	3.40
1.80V	156	118	96.2	61.8	41.7	17.5	12.1	6.51	3.28
1.85V	118	97	83.2	56.8	41.3	17.4	12.0	6.39	3.22

**Constant power discharge ratings-watts at 25°C**

F. V/Time	5MIN	10MIN	15MIN	30MIN	1HR	3HR	5HR	10HR	20HR
1.60V	375	259	202	129	84.5	34.1	23.7	13.8	6.85
1.67V	356	255	200	126	81.7	34.1	23.7	13.6	6.83
1.70V	332	249	196	123	79.6	34.1	23.7	13.5	6.83
1.75V	309	233	185	120	78.8	33.5	23.5	13.2	6.80
1.80V	278	216	174	116	77.5	33.1	23.1	13.0	6.56
1.85V	222	179	151	107	76.8	33.0	22.8	12.8	6.42

