

Deep Cycle SLA Battery

DC SERIES

DC (Deep cycle) Series batteries are designed for deep discharge application, with special chemical formula for plates active paste material, slightly stronger electrolyte and low temperature design, which can withstand repeated deep cyclic application, such as Solar Energy System, Golf Trolley, Electric

Application

- Solar Energy System
- Golf Cars and Buggies
- Electric Powered Vehicles
- Wheel Chairs
- Power Tools
- Electric Powered Toys
- Control System
- Vacuum Cleaners
- Medical Equipments
- UPS

General Features

- Sealed and maintenance free operation.
- Non-Spillable construction design.
- ABS containers and covers(UL94HB, UL94V-0) optional.
- Safety valve installation for explosion proof.
- High quality and high reliability.
- Exceptional deep discharge recovery performance.
- Low self discharge characteristic.
- Flexibility design for multiple install positions.

Construction

- ComponentRaw material
- PositiveLead dioxide
- NegativeLead
- ContainerABS
- CoverABS
- SealantEpoxy Resin
- Safety valveEPDR
- TerminalCopper
- SeparatorFibre glass
- ElectrolyteSulfuric acid

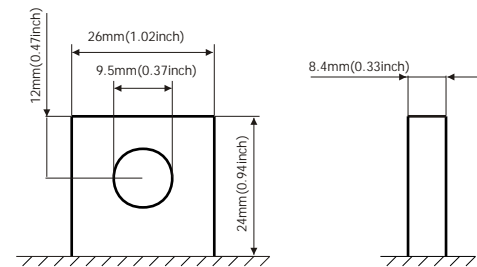

Terminal Dimensions

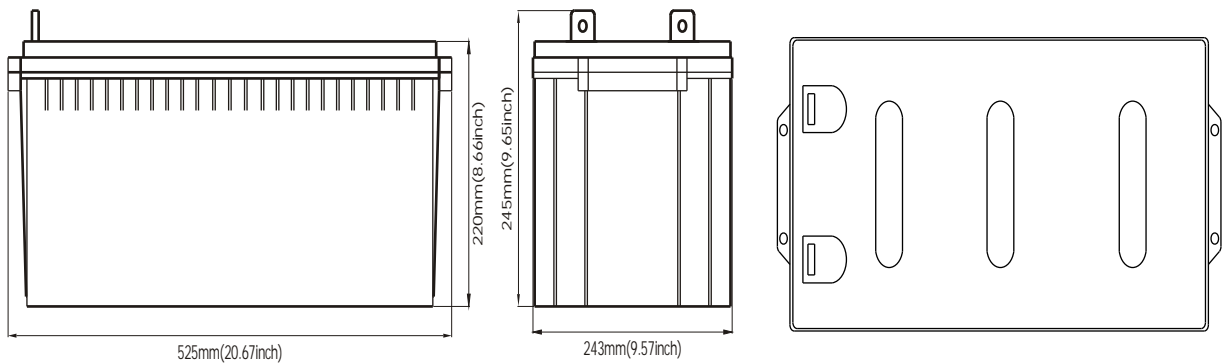

Battery Model	DC 12-200			
Designed Cycle Life	> 350 cycles @ -0.5CA to 9.6V			
Capacity(25°C)	20HR(10.1A,1.75V)	10HR(20A,1.75V)	5HR(34A,1.75V)	1HR(126A,1.75V)
	202AH	200AH	170AH	126AH
Dimensions	Length	Width	Height	Total Height
	525mm(20.67inch)	243mm(9.57inch)	220mm(8.66inch)	245mm(9.65inch)
Approx. Weight	63Kg (138.92 lbs)			
Internal Resistance	Full charged at 25°C: 0.004 Ohm			
Self Discharge	3% of capacity declined per month at (25°C)			
Capacity Affected by Temp.(20HR)	40°C	25°C	0°C	-15°C
	102%	100%	85%	65%
Charge Voltage(25°C)	Cycle use		Float use	
	14.4-15V(-30mV/ °C), max. Current: 50A		13.6-13.8V(-20mV/ °C)	

Deep Cycle SLA Battery

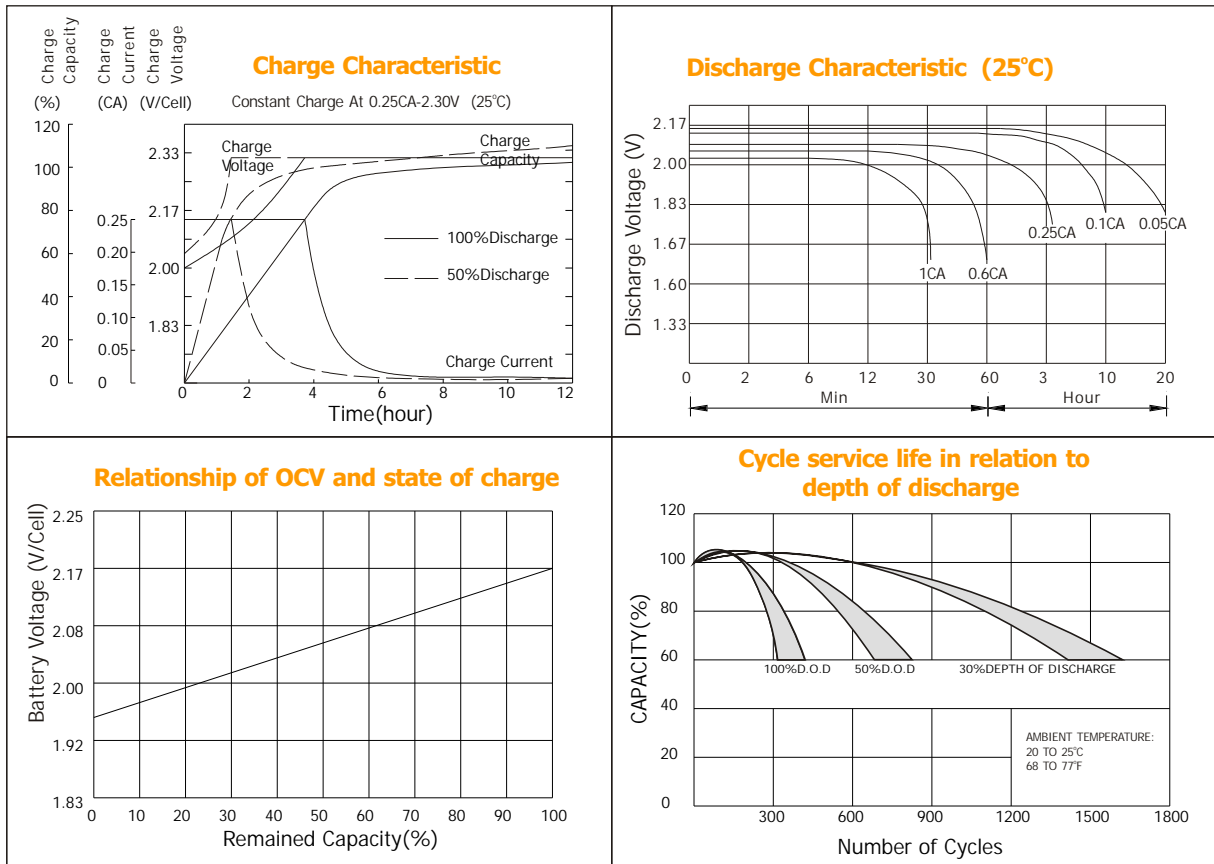

Constant current discharge ratings-amperes at 25°C

F. V/Time	5MIN	10MIN	15MIN	30MIN	1HR	3HR	5HR	10HR	20HR
1.60V	875	544	410	250	145.0	63.6	38.9	21.2	11.4
1.67V	821	516	395	239	143.1	61.2	38.1	21.0	11.0
1.70V	752	497	386	218	138.7	57.1	37.3	20.9	10.9
1.75V	737	482	373	207	132.2	55.2	36.4	20.8	10.6
1.80V	660	460	339	192	123.8	53.0	34.3	20.4	10.3
1.85V	582	438	305	176	115.3	51.1	32.1	19.8	10.0

Constant power discharge ratings-watts at 25°C

F. V/Time	5MIN	10MIN	15MIN	30MIN	1HR	3HR	5HR	10HR	20HR
1.60V	1534	983	749	451	262	113	65.7	43.5	22.8
1.67V	1480	958	740	442	260	109	65.5	43.2	22.0
1.70V	1394	948	734	414	255	104	64.6	43.0	21.8
1.75V	1403	945	728	401	251	102	64.0	42.4	21.4
1.80V	1283	931	675	382	236	99.0	62.1	41.1	20.7
1.85V	1164	884	612	358	222	96.0	60.1	38.7	20.0

